

CPB Discussion Paper

No 140

February 2010

Selective contracting and foreclosure in health care markets

Michiel Bijlsma^a, Jan Boone^b and Gijsbert Zwart^c

^a Netherlands Bureau for Economic Policy Analysis, CPB, PO Box 80510, 2508 GM The Hague, The Netherlands, e-mail: m.j.bijlsma@cpb.nl

^b CentER, TILEC, Department of Economics, Tilburg University, CPB and CEPR. Email: j.boone@uvt.nl.

^c TILEC, Tilburg University, and Netherlands Bureau for Economic Policy Analysis, CPB, PO Box 80510, 2508 GM The Hague, The Netherlands, e-mail: g.t.j.zwart@cpb.nl.

The responsibility for the contents of this CPB Discussion Paper remains with the author(s)

CPB Netherlands Bureau for Economic Policy Analysis

Van Stolkweg 14

P.O. Box 80510

2508 GM The Hague, the Netherlands

Telephone +31 70 338 33 80

Telefax +31 70 338 33 50

Internet www.cpb.nl

ISBN 978-90-5833-437-4

Abstract in English

We analyze exclusive contracts between health care providers and insurers in a model where some consumers choose to stay uninsured. In case of a monopoly insurer, exclusion of a provider changes the distribution of consumers who choose not to insure. Although the foreclosed care provider remains active in the market for the non-insured, we show that exclusion leads to anti-competitive effects on this non-insured market. As a consequence exclusion can raise industry profits, and then occurs in equilibrium. Under competitive insurance markets, the anticompetitive exclusive equilibrium survives. Uninsured consumers, however, are now not better off without exclusion. Competition among insurers raises prices in equilibria without exclusion, as a result of a horizontal analogue to the double marginalization effect. Instead, under competitive insurance markets exclusion is desirable as long as no provider is excluded by all insurers.

Keywords: health insurance, uninsured, selective contracting, exclusion, foreclosure, anti-competitive effects.

JEL classification: L42, I11, G22

Abstract in Dutch

We onderzoeken selectieve contracten tussen zorgaanbieders en zorgverzekeraars in een model waarbij niet alle consumenten zich verzekeren. Wanneer er slechts één verzekeraar is, beïnvloedt diens keuze om geen contract te sluiten met een zorgaanbieder de verdeling van consumenten die geen verzekering willen afsluiten. Hoewel de niet-gecontracteerde aanbieder in de markt actief blijft en zorg biedt aan onverzekerde consumenten, wordt de concurrentie op die markt voor niet-verzekerde consumenten minder fel. Daardoor kan de winst in de sector toenemen door selectieve contractering, en dit zorgt ervoor dat selectieve contracten in evenwicht afgesloten worden. Wanneer verzekeraars met elkaar concurreren, blijft zo een evenwicht met selectieve contracten bestaan. Maar onverzekerden gaan er niet op vooruit wanneer selectieve contracten verboden worden. Door horizontale dubbele marginalisatie stijgen dan de evenwichtsprijzen. Selectieve contracten zijn aantrekkelijker mits elke aanbieder een contract heeft met ten minste een van de verzekeraars.

Steekwoorden: Zorgverzekering, Onverzekerd, Selectieve Contracten, Uitsluiting, Anticompetitieve Effecten.

Contents

Summary	7
1 Introduction	9
2 The contracting game	15
3 Anti-competitive effects of exclusion	17
3.1 The model	17
3.2 Common equilibrium	18
3.3 Exclusive equilibrium	20
3.4 Example	23
4 Exclusive equilibria with two insurers	25
5 Discussion	29
6 Conclusions	31
References	33

Summary

Health care costs are growing faster than national income in most countries. Policy makers face the challenges of limiting the costs of health care while at the same time guaranteeing access to care. Selective contracting between insurers and health care providers is often presented as a way to meet these twin challenges. The health economics literature stresses that selective contracting increases insurers' bargaining power, because an insurer can credibly threaten to steer his customers away from a hospital that does not reduce its price. The option to enter into selective contracts allows insurers to extract more rents from providers, reducing their payments for treatments. This in turn leads, so it is claimed, to lower prices for insured treatments and hence lower health care costs. As health care expenditures are on the rise in most –if not all– developed countries, such reductions in treatment prices are welcome.

In this paper, we investigate this issue through the lens of the theory of exclusive contracts. We analyze exclusive contracts between two health care providers with market power and insurers. We consider a model where consumers can choose to stay uninsured. We first focus on monopoly insurance and show that exclusion of a care provider leads to anti-competitive effects that are mediated by the market for the non-insured. Exclusion can raise industry profits, and then occurs in equilibrium.

The insight of our paper that leads to anti-competitive effects of selective contracting is the externality of selective contracting on the non-insured market. An excluded provider with market power faces relatively many uninsured customers close to its location. For these consumers insurance is less attractive as they would have to travel far to receive insured care. Hence the excluded provider faces relatively many inframarginal consumers, which drives up the price for uninsured care at this provider. Assuming price competition, reaction functions are upward sloping and the contracted provider also raises its price for uninsured care. Hence we have anti-competitive effects even though the excluded provider does not leave the market. The final step is to observe that high prices for uninsured care make insurance more attractive. Excluding a provider can therefore raise industry profits, which is a necessary and sufficient condition for exclusion to take place. As mentioned, a necessary condition for such anti-competitive effects is that the excluded provider has market power on the uninsured market. If there is no such market power, selective contracting does not require intervention. If the excluded provider cannot raise the uninsured price due to competitive restraints the common outcome is more profitable for all firms involved than exclusion. Hence, in this case, we do not expect to see exclusive contracts in equilibrium.

When there is competition at the insurer level as well, more configurations of exclusive relations exist. Depending on which provider contracts with which insurer, outcomes with selective contracts may or may not be symmetric. We show that the same asymmetric exclusive outcome as that occurring under monopoly insurance persists in this case. On the other hand,

configurations where each provider has an exclusive contract with at least one insurer do not lead to such anti-competitive effects. In fact, these outcomes lead to cheaper insurance than in situations without selective contracts. The reason is that the common equilibrium is plagued by a double marginalization problem. Both providers' inputs are essential for an insurer to offer common contracts, but either hospital fails to take into account the reduction in its rival's profits that is due to a raise in its own transfer price.

The solution to these potentially anticompetitive effects is not to ban selective contracting, as the entire pattern of contractual relationships matters for determining the harmful or beneficial effects. The policy implication is instead that selective contracts should raise alarm bells if all insurers exclude a care provider with market power in the uninsured market.

We thank Albert Ma, Cédric Argenton, Jan-Kees Winters and seminar participants at TILEC, NZa, CPB, Erasmus University Rotterdam, University of Amsterdam, University of Groningen and EARIE 2009 for helpful comments. Jan Boone gratefully acknowledges financial support from the Netherlands Organisation for Scientific Research (NWO) through a Vici grant.

1 Introduction

Health care expenditure in OECD countries increases with 5 to 10% in real terms per annum. Policy makers face the challenges of limiting the costs of health care while at the same time guaranteeing access to care. The health economics literature suggests selective contracting between insurers and health care providers as a way to meet these twin challenges.

The argument goes as follows (see, for instance, Dranove and White, 1999, pp. 41 and Haas-Wilson, 2003, pp. 40). Health care providers have market power. For several reasons consumers do not shop around and search for the best price-quality combination.¹ In contrast, insurers do have an incentive to shop around for the lowest price as their search costs are spread over thousands of insured. Selective contracting increases the bargaining power of insurers vis-a-vis providers, because an insurer can credibly threaten to steer his customers away from a hospital that does not reduce its price. This allows insurers to extract more rents from providers by reducing their payments for treatments. Indeed, empirical work such as Town and Vistnes (2001) has confirmed such effects of selective contracting on bargaining power in the US. As long as there is enough competition in the insurance market, the benefit of such lower prices are then passed on to consumers, so the argument continues. Hence selective contracting is supposed to lead to lower treatment prices and lower insurance premia. In this way it reduces costs and makes insurance accessible to more consumers, thereby helping to meet the mentioned twin challenges.

In policy circles, these benefits of selective contracting are viewed with suspicion on the grounds that such contracts reduce choice for consumers, and perhaps inefficiently so. In the US there is an intense discussion on the trade-off between cost reduction and patient satisfaction (see e.g. Sloan et al., 2005). In reflection of this unsettled discussion, just over half of all US states have adopted Any-Willing-Provider or Freedom-of-Choice laws restricting the scope for selective contracting (Vita, 2001).

In many countries a market for uninsured care exists besides a market for insured care. In the US insurance is not mandatory. As a consequence, a large part of the population has no health care insurance. In other countries, like the Netherlands and Switzerland, health insurance is mandatory for “basic treatments”, but health insurance for other treatments is voluntary.

This creates an additional challenge. For people without insurance, health care should still be affordable for at least the following three reasons. First, if uninsured care is expensive, people may forgo treatments that are actually necessary (and efficient from a social point of view).

¹ First, consumers with insurance have a reduced (or even no) incentive to look for the lowest price. Second, even if a consumer has an economic incentive to shop around, he would do so only when he is ill. This tends to increase search costs which reduce the number of hospitals compared. Third, consumers may not have all relevant information to make the comparison. Hospitals do not tend to price per treatment but per service. This makes it hard for customers to understand ex ante what the price of a hospital will be (Dranove, 2000, pp. 73/4).

Second, we know that in a country like the US income and (having) health insurance are positively correlated. In the words of Gruber (2008, pp. 576) “the modal uninsured person is a member of what might be called the ‘working poor class’: below median income, but not among the poorest in the nation”. From an equity point of view it is undesirable that relatively poor people do not get treatment because they cannot afford it. Finally, government often ends up paying for care that is not paid for by other means. As estimated by Hadley and Holahan (2003, pp. 77), in 2001 US federal and state governments paid hospitals \$23.6 billion to cover uncompensated care for the uninsured.

We argue that in markets where insured and uninsured care coexist, selective contracting does not necessarily imply beneficial effects (only). We use insights from the literature on exclusive contracts (in particular, Bernheim and Whinston, 1998) to make the following three points. First, selective contracting can raise prices for uninsured care. Second, although in that case selective contracting can indeed lead to cheaper insurance, the reason for this is not that insurers pass on rents extracted from providers. It happens because insurers sell an inferior product (with reduced choice set of providers). In this sense selective contracting leads to a trade off in terms of the twin challenges above. It does make insurance cheaper, but people that (still) go without insurance are worse off. This last effect raises the probability of under-treatment for uninsured patients (see IOM, 2009, for a recent report on this). Third, the solution to these potentially anti-competitive effects is not to ban selective contracting. The structure of contractual relationships matters for determining the harmful or beneficial effects of selective contracts. For some types of selective contracts, harmful effects do not occur and insurance is cheaper than in the absence of selective contracts. The policy implication is that selective contracts should raise alarm bells if all insurers exclude a care provider with market power in the uninsured market.

In the health care literature, several papers capture the benefits of selective contracting. Gal-Or (1997) finds that with homogeneous insurers, there is no exclusionary equilibrium. Further, if (with insurer differentiation) there is an exclusionary outcome, consumers prefer this above the common outcome. Gaynor and Ma (1996) find that selective contracting does not lead to anti-competitive effects. These papers differ from our analysis in the following aspects. Gaynor and Ma (1996) and Gal-Or (1997) do not consider the non-insured market.² Gal-Or (1997) introduces a bargaining imperfection by ruling out two-part tariffs. This is not realistic as we know that combinations of capitation and fee for service contracts are used in health care. In particular, fear of supplier induced demand has led many insurers to use two-part tariffs. Gaynor and Ma (1996) do consider two-part tariff contracts and they allow for insurance contracts with co-payments, which we do not analyze. However, they consider given settings with and without exclusive contracts. The Bernheim and Whinston (1998) framework that we use allows us to

² A recent paper that also considers the effects of the non-insured on competition among insurers (but that does not address selective contracting) is Fombaron and Milcent (2007).

endogenize contract types by letting hospitals choose the type of contract they want to offer to the insurer. These differences turn out to be crucial.³

Selective contracting is a form of exclusion. The generally positive view on selective contracts in the health economics literature is in stark contrast to the Post-Chicago view on exclusive contracts in the industrial organization literature. This literature stresses the anti-competitive effects of exclusionary contracts. Aghion and Bolton (1987) point out that exclusive contracts may help an incumbent upstream and downstream firm to extract rents from an upstream entrant. Rasmusen et al. (1991) and Segal and Whinston (2000) point to a coordination failure among downstream firms through which exclusive contracts can be forced upon buyers although they are not in buyers' collective interest. The general insight from these papers is that exclusive contracts can be accepted in equilibrium while being detrimental for welfare due to the external effects of the contract on parties not present when contracts are negotiated.⁴

To analyze the effects of selective contracting, we stay within this industrial organization literature and use the Bernheim and Whinston (1998) framework. As in that paper, upstream firms - care providers - make contract offers to downstream firms, insurers. We deviate from their framework in three respects. First, all parties are symmetrically placed: no firm has to incur an entry cost and offers are made simultaneously by providers to insurers. Second, we assume that upstream providers can sell directly to final consumers; this is the market for uninsured care that we want to focus on. Third, whereas Bernheim and Whinston (1998) consider markets with two upstream firms and one downstream firm (with different downstream firms in consecutive markets), we also consider the case with two upstream and two downstream firms in one market.

The insight of our paper that leads to anti-competitive effects of selective contracting is the externality of selective contracting on the non-insured market (which is the non-coincident market in the terminology of Bernheim and Whinston, 1998). We model two hospitals that are differentiated on an Hotelling line. Geographic differentiation is a natural interpretation here, but it can also capture differences in treatments used or other aspects that some consumers like while others do not. If insurers contract with only one provider instead of two, the following happens. The excluded provider faces relatively many uninsured customers close to its location. For these consumers, insurance is less attractive as they would have to travel far to receive insured care.

³ A related paper on vertical integration –not on selective contracting– is Ma (1997). He considers markets where consumers buy options to consume. An example here is health insurance. He shows that vertical integration leads to foreclosure. However, his framework is different from ours as he assumes that consumers have to buy health insurance in order to be able to consume health care services. That is, there is no uninsured market in his model.

⁴ As pointed out by Spector (2007), in real world competition cases it is not always clear that these theories apply. In particular, the assumption that the party negatively affected by an exclusionary contract was not present at the time the contract was negotiated is often not satisfied. Hence this party should have made counter-offers to avoid the exclusionary contract being accepted. In our model it is the uninsured that are negatively affected by selective contracting. For obvious reasons, like free riding, it is natural to assume that the uninsured are not able to make counter offers when an insurer and provider bargain an exclusive deal.

Hence the excluded provider faces relatively many inframarginal consumers, which drive up the price for uninsured care at this provider. Assuming price competition, reaction functions are upward sloping and the contracted provider also raises its price for uninsured care. Hence we have anti-competitive effects even though the excluded provider does not leave the market.⁵ The final step is to observe that high prices for uninsured care make insurance more attractive. Excluding a provider can therefore raise industry profits, which is a necessary and sufficient condition for exclusion to take place (the first “general principle” in Bernheim and Whinston, 1998). As mentioned, a necessary condition for such anti-competitive effects is that the excluded provider has market power on the uninsured market. If there is no such market power, selective contracting does not require intervention. If the excluded provider cannot raise the uninsured price due to competitive restraints (and there are no efficiency gains due to exclusion) the common outcome is more profitable for all firms involved than exclusion. Hence, in this case, we expect to see the common outcome in equilibrium.

When there is competition at the insurer level as well, more configurations of exclusive relations exist. Depending on which provider contracts with which insurer, outcomes with selective contracts may or may not be symmetric. We show that the same asymmetric exclusive outcome as that occurring under monopoly insurance persists in this case. On the other hand, configurations where each provider has an exclusive contract (with at least one insurer) do not feature such anti-competitive effects. In fact, these outcomes lead to cheaper insurance than in situations without selective contracts. The reason is that the common equilibrium is plagued by a double marginalization problem. Both providers’ inputs are essential for an insurer to offer common contracts, but either hospital fails to take into account the reduction in its rival’s profits due to a raise in its own transfer price.

In section 2, we introduce the general contracting game that underlies our analysis of exclusive and common contracts. We show that the option of selective contracting indeed increases rents for insurers. However, this rent is transferred using the fixed part of the two-part tariff. Hence, the price per treatment is not reduced for the insurer and hence this effect does not reduce the insurance premium. In section 3 we present an explicit model of one insurer contracting with two differentiated healthcare providers and study the common and exclusive equilibrium of this model. We show that selective contracting can indeed have anti-competitive effects. In Section 4 we analyze what happens to our results if two competing insurers contract with two healthcare providers. We show that the anti-competitive effects of the exclusion outcome (with a monopoly insurer) do not disappear with insurer competition. Further, we show that banning selective contracting is not optimal either. Section 5 discusses the implications of our analysis and makes suggestions for future research. In our analysis we assume that selective

⁵ This result is reminiscent of Wright (2008) who finds that exclusionary contracts can be anti-competitive even if they do not foreclose entry, by changing the intensity of competition. We find a similar result through a different mechanism.

contracting does not affect providers' or insurers' efficiency and we focus on anti-competitive effects. In section 5 we return to this issue. Section 6 concludes. Proofs of results are in the appendix.

2 The contracting game

Before we specify the game determining insurance and provider prices, we look at the contracting game between a monopoly insurer and providers using reduced form profits. We characterize equilibria in selective contracts and derive conditions for equilibria without exclusion to exist. We then show that rent extraction from health care providers may indeed be a motivation for encouraging selective contracting by insurers, as claimed in the health care literature. This happens, however, via the fixed fee (in a two-part tariff) and is therefore unlikely (by itself) to lead to lower prices for health insurance.

We consider a market with two providers P_1, P_2 and one insurer I . This is the simplest set-up in which we can analyze the effect of exclusive contracting. The contracting game endogenizes the choice between exclusive and common (*i.e.* no exclusion) contracts, the (marginal) prices at which the insurer buys treatments from the provider and the fixed fees used to allocate the surplus realized among the various players.⁶ Following Bernheim and Whinston (1998), we make the crucial assumption that providers bilaterally negotiate with the insurer. Either provider can only observe whether the insurer has also contracted with its rival, but cannot observe the terms of this contract. Hence I and P_i can contract upon whether or not I deals with P_j ($j \neq i$). But they cannot contract upon the details of a contract between I and P_j .

Again following Bernheim and Whinston (1998), we assume that providers make the offers which the insurer may only accept or reject.⁷ First, we introduce some notation. In the case where the insurer has a contract exclusively with provider P_i , we denote equilibrium profits (excluding lump sum transfers) for insurer I , providers P_i and P_j ($j \neq i$) as $\pi_I^{(i)}, \pi_i^{(i)}, \pi_j^{(i)}$, implicitly assuming the choice of a transfer price \tilde{p}_i maximizing I 's and P_i 's bilateral profits.⁸ We also introduce $\Pi_{bilateral}^{(i)} = \pi_I^{(i)} + \pi_i^{(i)}$ and $\Pi_{total}^{(i)} = \pi_I^{(i)} + \pi_i^{(i)} + \pi_j^{(i)}$. With common representation the insurer has a contract with both providers. In that case we denote equilibrium profits by $\pi_I^c, \pi_i^c, \pi_j^c$ and $\Pi_{total}^c = \pi_I^c + \pi_i^c + \pi_j^c$. In the following we assume, without loss of generality, that $\Pi_{total}^{(1)} \geq \Pi_{total}^{(2)}$. In the next section we focus on the symmetric case where $\Pi_{total}^{(1)} = \Pi_{total}^{(2)}$.

We can now, by a straightforward extension of the arguments in Bernheim and Whinston (1998), prove the following

Lemma 1. *An exclusionary equilibrium always exists. If total sector profits are lower under*

⁶ In health care, two-part tariffs often take the form of a combination of capitation and fee-for-service payments (see, for example, Glied, 2000, pp. 714 and Scott, 2000, pp. 1188). When insurers bargain with hospitals, they bargain over a range of products (treatments). It is unlikely that this leads to linear pricing for each product separately.

⁷ The advantage of this assumption is that we do not need to specify the beliefs (wary, passive or otherwise) that P_i has with respect to the offer that I makes to P_j ($j \neq i$).

⁸ If \tilde{p}_i would not maximize joint profits, it is optimal for I and P_i to adjust \tilde{p}_i and use the fixed part of the tariff to distribute the additional profit between them.

common representation than under exclusive representation of P_1 , $\Pi_{total}^{(1)} > \Pi_{total}^c$, only an exclusive equilibrium exists. Payoffs in the exclusive outcome are

$$\begin{aligned} I &: \Pi_{bilateral}^{(2)} - \pi_2^{(1)} \\ P_1 &: \Pi_{total}^{(1)} - \Pi_{bilateral}^{(2)} \\ P_2 &: \pi_2^{(1)} \end{aligned}$$

If $\Pi_{total}^{(1)} \leq \Pi_{total}^c$, also a common equilibrium exists in which payoffs are

$$\begin{aligned} I &: \Pi_{bilateral}^{(1)} + \Pi_{bilateral}^{(2)} - \Pi_{total}^c \\ P_1 &: \Pi_{total}^c - \Pi_{bilateral}^{(2)} \\ P_2 &: \Pi_{total}^c - \Pi_{bilateral}^{(1)} \end{aligned}$$

Both providers compete to become the exclusive provider. In equilibrium the rents left to the insurer should be sufficiently high to leave the excluded provider P_2 indifferent between having a contract and being excluded from insured care. That is, if the coalition of P_2 and I would deviate and sign a bilateral exclusive contract they would earn $\Pi_{bilateral}^{(2)}$. Indeed, this is also what they earn (together) in the outcome where P_1 is the exclusive provider.

The mere possibility of an exclusive deal also serves to restrict rent extraction by the providers under common representation. If under common representation a provider insists on too large a fraction of the rents, its rival and the insurer have a mutual interest in deviating to an exclusive contract, sharing the resulting rents to leave both better off. Again if I and P_i were to deviate to an exclusive contract, they would jointly earn $\Pi_{bilateral}^{(i)}$, which by lemma 1 equals their bilateral profit in the common outcome. Note that if total profits under exclusion are higher than under common representation, there is always an incentive to deviate from the common contract. In that case, there is no equilibrium with common representation.

If an equilibrium with common representation exists, the possibility of selective contracting increases the rents left to the insurer by creating a valuable outside option. Selective contracting therefore helps in extracting rents from providers with market power. Formally, we have the following.

Lemma 2. *If $\Pi_{total}^{(1)} < \Pi_{total}^c$, so that there exist both exclusionary and common equilibria, the insurer's profits are higher under the exclusive equilibria.*

At first sight, this might provide a rationale for the benevolence of policymakers towards selective contracting: it is through the insurer channel that rents are extracted from health care providers. The rent extraction, however, occurs through the fixed transfer and not the price per treatment. Therefore, one should not expect that these rents are passed on to the consumers.

In the remainder of this paper we expand on reasons why $\Pi_{total}^{(1)} > \Pi_{total}^c$, leading to exclusive equilibria. Exclusion in the insurance market may raise industry profits because it affects providers' behavior in the adjacent market of health care for the non-insured.

3 Anti-competitive effects of exclusion

In this section, we introduce a model of the health care market and the health insurance market with two providers and one insurer. We characterize treatment prices and the insurance premium in the common and exclusive outcomes. We show that exclusionary contracts can have anti-competitive effects in the presence of an adjacent market of health care for the non-insured.

3.1 The model

Risk averse consumers can either buy health insurance, in which case the insurer pays for treatment costs in case of illness, or go without insurance and pay for treatments themselves (if needed). For simplicity, we assume that health insurance provides full coverage of (monetary) health expenditures.⁹ Providers are differentiated, which we model with a Hotelling beach. A natural interpretation is that providers are spatially differentiated, but other forms of differentiation in product space are captured as well. Consumers are uniformly distributed on the Hotelling line of length one. Provider P_1 is located on the far left and P_2 on the far right. Consumers know their preference for either hospital (i.e. their location on the Hotelling line), and are aware of which providers the insurer has contracted with.¹⁰ If the insurer has an exclusive contract with one provider, we assume that insured customers can only go to that provider and get their costs reimbursed. Hence, under exclusion, all insured consumers in need of care will visit the exclusive hospital.

We assume the following timing of the game:

1. The providers P_i offer the insurer I contracts with the following features: a price per treatment \tilde{p}_i , a fixed transfer and possibly an exclusivity clause;
2. The insurer decides on which contract(s) to accept;
3. The insurer chooses the insurance premium ϕ ;
4. The consumers choose whether or not to buy insurance;
5. The providers decide on prices p_i for uninsured treatments.

Once the insurer and providers agree on prices and contract terms, the insurer knows what expected treatment costs will be and hence can calculate the optimal insurance premium. Once

⁹ Clearly, if insurers can offer partial coverage, they may be able to price-discriminate among different types more effectively and by doing so raise their profits.

¹⁰ Others, like Gal-Or (1997), assume that consumers do not know ex ante which provider they will prefer in case they need treatment. Either assumption is plausible depending on the treatment and the form of differentiation between providers. If we interpret our Hotelling beach as geographic differentiation, it is well known that people prefer hospitals that are close. In the words of Capps et al. (2003, pp. 739) "Many patients, especially those with conditions that are relatively straightforward to treat, have a strong preference to go to a convenient, nearby hospital". This preference consumers know when choosing insurance.

the premium is known, consumers can decide whether or not to buy insurance. Finally, providers choose prices for uninsured care. That is, nothing stops providers from adjusting prices for uninsured care after consumers have decided whether or not to buy health insurance. Put differently, providers cannot commit to uninsured prices in the early stages of the game.

The cost of treatment is the same for both providers and equal to $c \geq 0$. An agent gets a negative health shock $\gamma > c$ with probability $1 - F$. Treatment reduces this disutility to zero and is thus socially efficient (as $\gamma > c$). Apart from the consumers' position x on the Hotelling beach, we introduce one more dimension of information asymmetry: consumers differ in their degree of risk aversion, measured by the parameter $\sigma \in [0, \bar{\sigma}]$ with distribution function $G(\cdot)$ and density function $g(\cdot)$. We assume an atomless distribution $G(\sigma)$ which is independent from x .

Expected utility costs of a consumer without insurance are the price charged by the health care provider and the travel cost to the provider plus σ times the variance of the expected costs. The expected disutility for a consumer located at x of relying on non-insured care from provider P_1 is therefore given by

$$E(p_1 + tx) + \sigma V(p_1 + tx)$$

where the expectation is over the probability $1 - F$ of falling ill. The expected costs for a consumer with insurance when going to provider 1 are

$$\phi + E(tx) + \sigma V(tx)$$

Recall that insurance covers the price of treatment, not the travel cost. Since travel costs can be in product space this is a reasonable assumption. Similar expressions, with x replaced by $1 - x$, obtain for consumers going to provider P_2 .

3.2 Common equilibrium

Let us first consider a common equilibrium where the insurer contracts with both providers. We analyze the model by backward induction. Given ϕ , we solve for the symmetric equilibrium in provider prices for the non-insured, p_c . Consumers choose whether to insure before these prices are set. We assume rational expectations on the part of consumers. Suppose consumers expect a pair of prices $\hat{p}_c = \hat{p}_1 = \hat{p}_2$ for uninsured treatments. They then decide whether or not to take insurance based upon their risk aversion parameter σ . Specifically, there will be a threshold value for σ that depends on \hat{p}_c , ϕ and varies with x . Only those with risk aversion above this threshold value will choose to insure. Consumers on the left-hand-side of $x = 1/2$ choose between paying a premium ϕ for insurance, or not taking out insurance and paying \hat{p}_c to provider 1 when they get sick. The threshold $\sigma(x, \phi, \hat{p}_c)$ is defined by

$$\phi + E(tx) + \sigma(x, \phi, \hat{p}_c) V(tx) = E(\hat{p}_c + tx) + \sigma(x, \phi, \hat{p}_c) V(\hat{p}_c + tx)$$

or, defining $\tilde{\phi} \equiv \phi/(1-F)$

$$\sigma(x, \phi, \hat{p}_c) = \frac{\tilde{\phi} - \hat{p}_c}{F(\hat{p}_c^2 + 2\hat{p}_c t x)} \quad (3.1)$$

A similar expression obtains, with x replaced by $1-x$ for consumers on the right-hand-side of $x = 1/2$. Note that $\frac{\partial}{\partial x} \sigma(x, \phi, \hat{p}_c) < 0$ (for $x < \frac{1}{2}$), *i.e.* you run more risk (in terms of costs) if you are further away from the provider and hence insurance becomes more attractive.

The providers then choose prices given the profile of non-insured. The profit of provider P_1 from uninsured consumers if it charges p_1 is given by

$$(1-F) \int_0^{\bar{x}} G(\sigma(x, \phi; \hat{p}_c)) (p_1 - c) dx$$

where $\bar{x} = \frac{1}{2} + \frac{p_2 - p_1}{2t}$, and similarly for P_2 . The first-order condition for providers P_1, P_2 in a symmetric equilibrium where $p_1 = p_2 = p_c$ then reads

$$p_c - c = 2t \frac{\int_0^{\frac{1}{2}} G(\sigma(x, \phi, \hat{p}_c)) dx}{G(\sigma(\frac{1}{2}, \phi, \hat{p}_c))}$$

Clearly, for x -independent σ we have the standard Hotelling equilibrium price $p_c - c = t$.

Rational expectations requires this first order condition to hold for $\hat{p}_c = p_c$,

$$p_c - c = 2t \frac{\int_0^{\frac{1}{2}} G(\sigma(x, \phi, p_c)) dx}{G(\sigma(\frac{1}{2}, \phi, p_c))} \quad (3.2)$$

The solution will in general be a function of ϕ : $p_c(\phi)$.¹¹

We now turn to the earlier stages of the game. Both insurer and providers will correctly anticipate the relation between ϕ and prices for the non-insured, $p_c(\phi)$. In the contracting stage, each provider will want to make sure that it optimizes its joint profits with the insurer (since surplus can be transferred between them through the fixed parts of the two-part tariffs); the instruments available to the providers for achieving this joint profit optimization are their respective linear components of the two-part tariffs, the transfer prices \tilde{p}_i . Moreover, joint profit optimization is subject to the insurer optimizing its individual profits by choosing ϕ .¹²

To make the optimization program explicit, we have the insurer's profits:

$$\frac{\pi_I}{1-F} = 2 \int_0^{\frac{1}{2}} (1 - G(\sigma(x, \tilde{\phi}, p_c))) dx \left[\tilde{\phi} - \frac{\tilde{p}_1 + \tilde{p}_2}{2} \right]$$

The insurer optimizes this profit over the insurance premium ϕ (taking into account also the effect on p_c). The insurer's optimal choice of ϕ is a function of both \tilde{p}_i 's. The profits for

¹¹ Note that we impose subgame perfection here. If $p_c > \tilde{\phi}$, everyone buys insurance and p_c is undetermined. Hence $p_c > \tilde{\phi}$ can be a Nash equilibrium. But it is not subgame perfect in the following sense. Consider a customer at $x = \frac{1}{2}$ who deviates from this equilibrium by not buying insurance. He should expect p_c to satisfy equation (3.2). If he is the only one to deviate, this boils down to $p_c = c$.

¹² We assume ϕ itself is not contractible for providers. In other words, I cannot commit to ϕ when bargaining with P_1 and P_2 .

provider P_1 equal the sum of profits from the non-insured consumers plus the income from treating insured consumers

$$\frac{\pi_i}{1-F} = \int_0^{\frac{1}{2}} G(\sigma(x, \phi, p_c)) dx (p_c - c) + \int_0^{\frac{1}{2}} [1 - G(\sigma(x, \phi, p_c))] dx (\tilde{p}_i - c)$$

so that joint profit of insurer and provider P_i is

$$\frac{\pi_I + \pi_i}{1-F} = 2 \int_0^{\frac{1}{2}} (1 - G(\sigma(x, \phi, p_c))) dx \left[\tilde{\phi} - \frac{c + \tilde{p}_j}{2} \right] + \int_0^{\frac{1}{2}} G(\sigma(x, \phi, p_c)) dx (p_c - c)$$

with both ϕ and p_c determined by the transfer prices \tilde{p}_i .

Summarizing, we have the following result.

Lemma 3. *In a common equilibrium, P_i 's treatment price p_c for non-insured patients is given (implicitly) by equation (3.2). The price \tilde{p}_i paid by I for treatment of one of its customers at P_i is chosen so that the insurer's profit maximizing choice of ϕ (also) maximizes bilateral profits of I and P_i (with $i = 1, 2$).*

3.3 Exclusive equilibrium

In this subsection, we analyze exclusive contracting with one provider, which we take to be provider P_1 without loss of generality. If the insurer only contracts with P_1 , this will change the density of customers choosing insurance in an asymmetric way. A customer on the right-hand side now has to choose between taking insurance and incurring the additional costs of traveling to provider P_1 on the one hand, and not taking insurance and going to the nearby provider P_2 on the other. This causes the equilibrium distribution of non-insured consumers to be skewed. The density of non-insured on the right-hand side will be larger than on the left-hand side. As a result, the two providers' prices are no longer symmetric, $p_1 \neq p_2$, and as $\sigma(x)$ is now steeper for consumers close to provider P_2 , the latter will have a larger incentive to raise its price p_2 . Since the two goods are strategic complements, this tends to raise p_1 as well. Hence we find that selective contracting leads to anti-competitive effects even if the "excluded" provider does not leave the market.

We now make this argument explicit. Again, first we focus on the final stage to find the (rational expectations) asymmetric equilibrium with $p_2 > p_1$. Suppose that consumers expect a pair of prices $\hat{p}_2 > \hat{p}_1$ for uninsured treatment. Consumers to the left of $\hat{x} = \frac{1}{2} + \frac{\hat{p}_2 - \hat{p}_1}{2t}$ will then go to provider P_1 , whether or not they are insured. They face the same choice as under the common equilibrium resulting in the same threshold function for σ

$$\sigma(x, \phi; \hat{p}_1, \hat{p}_2) = \frac{\phi - E(\hat{p}_1)}{V(\hat{p}_1 + tx) - V(tx)} = \frac{\tilde{\phi} - \hat{p}_1}{F(\hat{p}_1^2 + 2\hat{p}_1 tx)} \text{ for } x < \hat{x} \quad (3.3)$$

The situation is different, however, for $x > \hat{x}$. Here, consumers trade-off the costs of insurance and going to provider P_1 against the costs of no insurance compensated by lower travel

costs (and going to provider P_2):

$$\phi + E(tx) + \sigma(x, \phi; \hat{p}_1, \hat{p}_2)V(tx) = E(\hat{p}_2 + t(1-x)) + \sigma(x, \phi; \hat{p}_1, \hat{p}_2)V(\hat{p}_2 + t(1-x))$$

so we have

$$\sigma(x, \phi; \hat{p}_1, \hat{p}_2) = \frac{\tilde{\phi} - (\hat{p}_2 + t) + 2tx}{F\left((\hat{p}_2 + t)^2 - 2(\hat{p}_2 + t)tx\right)} \text{ for } x > \hat{x} \quad (3.4)$$

Note that $\sigma(x, \phi; \hat{p}_1, \hat{p}_2)$ is continuous at $x = \hat{x}$. Further, this expression is only valid if $\tilde{\phi} - \hat{p}_1, \tilde{\phi} - (\hat{p}_2 + t) + 2tx > 0$.¹³

Given consumers' choices whether or not to buy insurance, i.e., given the profile of non-insured, the health care providers choose prices to optimize their profit from the uninsured consumers. Rational expectations once more imply that $p_i(\hat{p}_1, \hat{p}_2) = \hat{p}_i$. To determine $p_i(\hat{p}_1, \hat{p}_2)$, we consider again the first order condition for provider P_i given expected prices \hat{p}_2, \hat{p}_1 . The profit of provider 1 from uninsured consumers now reads

$$\int_0^{\bar{x}} G(\sigma(x, \phi; \hat{p}_1, \hat{p}_2))(p_1 - c) dx$$

where $\bar{x} = \frac{1}{2} + \frac{p_2 - p_1}{2t}$. Prices consistent with rational expectations now satisfy

$$p_1 - c = 2t \frac{\int_0^{\bar{x}} G(\sigma(x, \phi; p_1, p_2)) dx}{G(\sigma(\bar{x}, \phi; p_1, p_2))} \quad (3.5)$$

$$p_2 - c = 2t \frac{\int_{\bar{x}}^1 G(\sigma(x, \phi; p_1, p_2)) dx}{G(\sigma(\bar{x}, \phi; p_1, p_2))}$$

where also $\bar{x} = \hat{x}$.

Again, in general these prices depend on ϕ . Let us call the solution $p_i(\phi)$. To ease notation, we define $\sigma(x, \phi) = \sigma(x, \phi; p_1(\phi), p_2(\phi))$. We have the insurer's profits:

$$\frac{\pi_I}{1-F} = \int_0^1 (1 - G(\sigma(x, \phi))) dx (\tilde{\phi} - \bar{p}_1)$$

where \bar{p}_1 is the transfer price. The insurer and the provider P_1 now jointly choose the transfer price \bar{p}_1 so as to achieve a ϕ that optimizes their bilateral profits,

$$\frac{\pi_I + \pi_1}{1-F} = \int_0^1 (1 - G(\sigma(x, \phi))) dx [\tilde{\phi} - c] + \int_0^{\bar{x}(\phi)} (G(\sigma(x, \phi))) dx [p_1(\phi) - c] \quad (3.6)$$

We can simplify this expression by using the first-order conditions (3.5) for the prices to eliminate the integrals. We have

$$\frac{\pi_I + \pi_1}{1-F} = \tilde{\phi} - c - \frac{1}{2t} G(\sigma(\bar{x}, \phi)) ((p_1 - c)(\tilde{\phi} - p_1) + (p_2 - c)(\tilde{\phi} - c))$$

with p_i given, as a function of ϕ , by (3.5). As equations (3.5) imply that $p_1, p_2 \geq c$, $\tilde{\phi} \leq c$ would imply that joint profits of I and P_1 are non-positive. This is clearly not optimal and hence we have

$$\tilde{\phi} > c \quad (3.7)$$

¹³ If the expression for σ turns negative, it means that there is an interval $[\bar{x}_I, \bar{x}_r]$ on the Hotelling beach where everyone is insured. We do not consider this case.

Summarizing this analysis, we have

Lemma 4. *In an exclusive equilibrium, P_1 's treatment price p_i for non-insured patients is determined (implicitly) by equations (3.5). The price paid by I for treatment of one of its customers at P_1 equals \tilde{p}_1 , which is chosen so as to achieve a ϕ that optimizes bilateral profits of the insurer and provider P_1 .*

We can next compare the prices for the non-insured under the exclusive and the common equilibrium. First we demonstrate that the asymmetric exclusive equilibrium helps to raise uninsured prices (for given choice of ϕ).

Proposition 1. *For a given $\phi \geq (1-F)c$, let $p^c(\phi)$ denote the solution to equation (3.2) and $p_1^e(\phi), p_2^e(\phi)$ the solution to equations (3.5). Assuming $p^c(\phi)$ is a function, we find that*

$$p_1^e(\phi) < \frac{\phi}{1-F} \text{ and } p^c(\phi) < p_1^e(\phi) < p_2^e(\phi) \quad (3.8)$$

The intuition behind this result is that, under exclusion, relatively many uninsured are close to the excluded provider P_2 . That is, P_2 faces many inframarginal, non-insured, consumers who are reluctant to go to P_1 . This raises P_2 's price on the non-insured market. Since providers compete in prices, reaction functions are upward sloping. Consequently, p_1 is higher in the exclusive outcome as well. Hence for given ϕ exclusive contracts soften competition between hospitals in the market for uninsured care. Note though, that in equilibrium ϕ will be different in the exclusive and common outcomes.

We are now ready to show our main result. The desire to strategically influence prices for the non-insured (and the consequences of these prices for total sector profits) is indeed the driver of exclusive outcomes. To demonstrate this, we argue that if for some exogenous reason prices for the non-insured are prevented from rising, the common outcome will always dominate selective contracting for the three firms I, P_1, P_2 . That is, industry profits are higher under common than under selective contracting. Let p_r denote an (exogenously specified) upper-bound for P_2 's price for non-insured care.¹⁴ Below we give four interpretations of p_r .

Theorem 1. *Suppose $p_2 \leq p_r$ is binding in the common equilibrium. Then the common equilibrium always dominates selective contracting.*

One interpretation of p_r is that prices for non-insured health care are regulated. The health care regulator has stipulated that the price cannot exceed p_r . A second interpretation is that intense

¹⁴ The upper bound p_r can apply to p_1 as well, the proof does not depend on this. However, the important issue is whether p_2 can rise in response to exclusion.

competition $t = 0$ between providers P_1 and P_2 results in $p_r = c$. Providers are not able to raise uninsured prices above marginal costs c due to intense price competition. Third, consider the case where P_1 and P_2 can collude on the monopoly price in the non-insured market. Assume t is low enough that the monopoly price under common representation is given by $\gamma - \frac{1}{2}t$. In these three cases the upper bound p_r applies to p_1 as well. As a final example, consider the case where p_r is only binding for p_2 . This happens, for instance, if there is a third provider P_3 also at position $x = 1$ offering the same service as P_2 at costs $c_3 \geq c$. In that case $p_r = c_3$. For c_3 close enough to c , this constraint is binding and $p_2 = c_3$ under both common and exclusive contracts.

In each of these four cases the proof of theorem 1 implies that selective contracting will not be used.

Hence, in our set up selective contracting is only profitable if it allows the providers to push up non-insured prices. If this is not feasible, for example due to regulation or intense competition, or no longer desirable, for example because providers already charge the monopoly price, common representation dominates selective contracting. In this sense, selective contracting is used by providers and insurer for its anti-competitive effects.

As the next subsection illustrates, although uninsured care becomes more expensive, this does not imply that insurance becomes more expensive as well. Intuitively, insurance is now an inferior product for people living close to the excluded provider. To convince these customers to buy insurance, the price may have to fall.

3.4 Example

We now discuss an explicit example with uniform distribution $G(\sigma) = \frac{\sigma}{\bar{\sigma}}$ with $\sigma \in [0, \bar{\sigma}]$ and choose $c = 0$. Assume that in equilibrium, $0 < \sigma(x, \phi) < \bar{\sigma}$. The first order condition for the provider in a common equilibrium then reads

$$p_c = (p_c + t) \log \left(1 + \frac{t}{p_c} \right) \quad (3.9)$$

This can be written as

$$p_c = \frac{bt}{1-b} > t \quad (3.10)$$

where b solves $b = -\log(b)$, which implies $b \approx 0.6$. Note that p_c is independent of ϕ . Then the bilaterally optimal transfer price equals $\tilde{p}_i = p_c$. The first order condition for the optimal ϕ then yields

$$\tilde{\phi}_c = p_c \left(1 + \frac{Ft\bar{\sigma}}{2b} \right). \quad (3.11)$$

Next, consider the case of an exclusive contract between the insurer and provider P_1 . The first order conditions become

$$p_1 = (p_2 + t) \log \left(\frac{p_2 + t}{p_1} \right) \quad (3.12)$$

Figure 3.1 Distribution of uninsured in common and exclusionary equilibrium with $G(\sigma) = \sigma/\bar{\sigma}, c = 0, t = 1, F\bar{\sigma} = 2$.

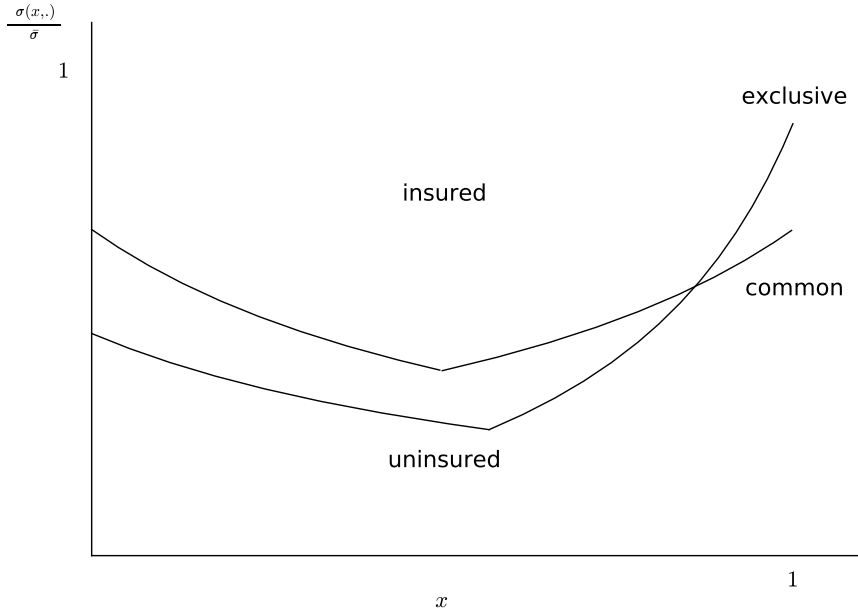

$$p_2 = \frac{p_1}{\tilde{\phi} - p_1} \left[\tilde{\phi} \log \frac{p_1}{p_2 - t} - (p_1 - p_2 + t) \right] \quad (3.13)$$

which can be written as

$$p_1 = b(t + p_2) \quad (3.14)$$

$$p_2 = \frac{b(t + p_2)}{\tilde{\phi} - b(t + p_2)} \left(\tilde{\phi} \log \left(\frac{b(t + p_2)}{p_2 - t} \right) - (b + 1)t + (1 - b)p_2 \right). \quad (3.15)$$

Figure 3.1 shows the distribution of uninsured for both the common and exclusionary equilibrium for the case where $t = 1, F\bar{\sigma} = 2$. As mentioned, $\sigma(x, \cdot)$ is decreasing in $x < \frac{1}{2}$ as people further away from P_1 have higher travel costs and hence face more risk. This makes insurance more attractive. Note that under exclusion P_2 's ratio of inframarginal over marginal consumers exceeds the same ratio under common contracts, where the marginal uninsured consumer is at the cusp of the line $\sigma(x, \cdot)$. In this example we find $\phi_c = 3.62, p_c = 1.31$ and $\phi_e = 3.51, p_1 = 1.49, p_2 = 1.62$.

Hence the price for uninsured treatments increases because of selective contracting (and more so for p_2 than for p_1) due to the skewed distribution of uninsured consumers over the Hotelling line. Provider P_2 faces many inframarginal consumers (relative to marginal ones) and hence raises p_2 . As prices are strategic complements, p_1 increases as well. Insurance under selective contracting is an inferior product for customers close to P_2 . To induce these people to buy insurance as well, compared to the common equilibrium I lowers ϕ in the exclusive outcome. Consumers not too close to provider 2 buy more insurance under exclusion. For these consumers the price for uninsured treatment is higher and ϕ is lower in the exclusion equilibrium as compared to the common outcome.

4 Exclusive equilibria with two insurers

So far, we have focused on the case with one insurer. One might think that the introduction of competition at the insurer level limits the scope for anticompetitive behavior. In this section we therefore explore the case of two (ex ante) undifferentiated insurers who engage in Bertrand competition. Although this drastically changes the providers' bargaining positions, and hence the allocation of the producer surplus, we demonstrate that the exclusive outcome above, and the associated anti-competitive effects persist in this setting. We also analyze the common outcome under downstream competition and find that it suffers from a (horizontal) double marginalization inefficiency which raises insurance prices even above the industry profit maximizing prices. A ban on selective contracting is therefore clearly not desirable. In fact, we demonstrate that an alternative, symmetric outcome with selective contracts is preferable. This outcome, where no provider is excluded from insurance, allows consumers to insure and choose their preferred provider. And insurance is cheaper than under common contracts.

Figure 4.1 Two ways to get exclusion with two insurers and two providers.

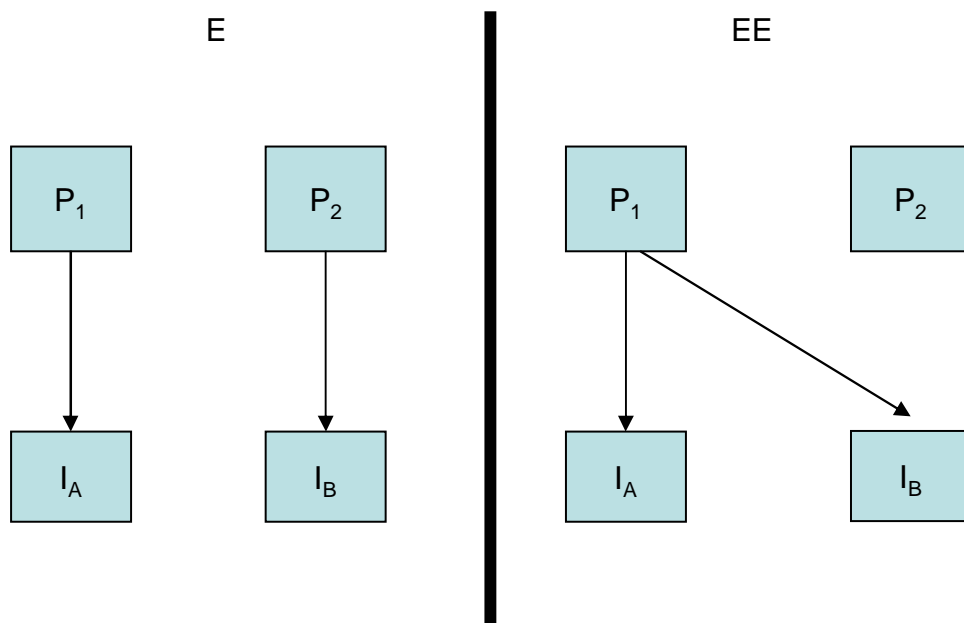

With two insurers, we consider two types of exclusion outcomes as illustrated in figure 4.1.¹⁵ In the first (symmetric) case P_1 contracts exclusively with I_a , and P_2 contracts exclusively with I_b . We denote this outcome by E . In this case insurers I_a and I_b offer differentiated products and hence are able to raise their premiums above costs. The other type of exclusive outcome is where P_1 contracts exclusively with both I_a and I_b . This outcome is denoted by EE . Here I_a and I_b offer

¹⁵ To check the stability of the outcomes, we consider a third, hybrid case in the appendix that we denote CE .

homogeneous goods and Bertrand competition implies pricing at marginal costs:

$\phi = (1 - F)\tilde{p}_1^{ee}$, where \tilde{p}_1^{ee} denotes the price per treatment that insurers pay to P_1 .

The next result shows that the EE outcome is the same as the exclusive equilibrium in the monopoly insurer case. Moreover, it is an equilibrium outcome if the exclusion outcome is an equilibrium in the monopoly insurer case. In this sense, the results we describe in section 3 are robust to the introduction of insurer competition.

Proposition 2. *Assume that inequality $\Pi_{total}^{(1)} > \Pi_{total}^c$ in lemma 1 holds. Then the exclusive outcome of lemma 4 is an equilibrium in the case with two insurers as well. This equilibrium is implemented in the EE outcome.*

As we show in theorem 1 the goal of the selective contract is its anti-competitive effect. By creating a skewed distribution of uninsured consumers, prices for uninsured treatments increase. This increase in uninsured prices further makes insurance more attractive. This intuition also applies with competing insurers.

At first sight, it looks attractive to avoid this EE outcome by banning exclusive contracts. However, this is not a good idea. The prices with common contracts in case of insurer competition are actually higher than with common contracts and a monopoly insurer. We consider a symmetric equilibrium here with common contracts.¹⁶

Proposition 3. *The insurance premium with two perfectly competitive insurers and common contracts will be higher than the insurance premium with a monopolist insurer and common contracts.*

The intuition for this result is a horizontal analogue of double marginalization. To see this, consider the case where provider i charges \tilde{p}_i per treatment to each insurer. Since consumers are insured, they will always choose the closest provider in case they need treatment. That is, the insured market splits at $\frac{1}{2}$. Bertrand competition on the insurance market with insurers offering homogeneous products then implies $\phi = \frac{1}{2}(1 - F)(\tilde{p}_1 + \tilde{p}_2)$. Hence when provider P_1 increases \tilde{p}_1 he reduces insured demand for P_2 . Provider P_1 overlooks this negative externality and hence raises \tilde{p}_1 and thereby ϕ above the level that is optimal with a monopoly insurer. A monopoly insurer makes a profit of his own and internalizes this externality. It can use transfers to solve the double marginalization problem and hence prices are lower. In fact, with a monopoly insurer \tilde{p}_i

¹⁶ Assume that P_2 offers \tilde{p}_2 to both I_a and I_b . If P_1 would offer a different transfer price to I_a than the price it offers to I_b , the insurer with the higher price would be out of business, leading to –de facto– exclusion. To see this, note that an insurer who faces transfer prices \tilde{p}_1, \tilde{p}_2 has to price at least at $\phi = \frac{1}{2}(1 - F)(\tilde{p}_1 + \tilde{p}_2)$ to avoid losses (as insured consumers go to the closest provider). Because in the common equilibrium I_a and I_b offer identical products, they need to have the same costs to both survive.

($i = 1, 2$) and ϕ are set to maximize industry profits (see lemma 5 in the appendix). Note that, if the number of providers increases, this externality becomes stronger and hence prices under common representation higher.

Therefore the implication of our analysis is not to ban exclusive contracts. The following result demonstrates that outcome E is actually the preferable one.

Proposition 4. *Assume that both in the common case with monopoly insurer and in case E there is a unique symmetric equilibrium. Then insurance premia are lower in outcome E than in the common outcome with a monopoly insurer, and a fortiori lower than those prevailing in the common outcome with insurer competition.*

The result is driven by the fact that $\partial p_i / \partial \phi_b \geq 0$ in the symmetric equilibrium, as we demonstrate in the proof. This is intuitive since insured care and uninsured care are substitutes competing in prices. As usual, reaction functions in prices are upward sloping. The monopoly insurer choosing the insurance price ϕ for all consumers to maximize industry profits (lemma 5 in the appendix) takes this effect of ϕ on non-insured prices into account. In case E, the combination P_1 and I_a overlooks this positive externality on P_2 and I_b . Hence they do not raise ϕ (and thereby p_1, p_2) to the same extent.

Summarizing, we have the following results. If there is a monopoly insurer, exclusive contracts lead to anti-competitive effects compared to the common outcome (theorem 1). With competing insurers, an outcome with exclusive contracts can be better from a social point of view than the common outcome if the exclusive contracts are “equally distributed” over providers (outcome E). More generally, the policy implication is that the concentration of exclusive contracts over providers should be low. If –in contrast– exclusive contracts are concentrated among providers, then a provider with no contracts faces relatively many inframarginal uninsured customers. This leads to a high uninsured price for this provider. Because of upward sloping reaction functions, other providers will increase their uninsured prices as well. This does not happen if the excluded provider does not have the (market) power to raise its uninsured price.

5 Discussion

In the analysis above, we assumed that no efficiency gains from selective contracting exist. In practice, selective contracting can enhance efficiency because of several reasons. For instance, one provider may offer a low quality service at a high cost. It may then be socially optimal to exclude this provider. Alternatively, investments may be specific to the relation between a particular provider and insurer. If the provider has to make these investments and there is a risk of free riding by other providers contracting with the same insurer, the level of investments will be suboptimal. Selective contracting can then help to increase such investments. What are our policy recommendation taking efficiency gains into account?

Theorem 1 shows that anti-competitive effects are absent if the excluded provider faces “enough” competition on its uninsured market. Hence if insurers exclude such a provider, an efficiency rationale for the exclusion must exist. In such a case there is no need to intervene for a competition authority or regulator. In practice, this can be the case when two (or more) nearby hospitals offer the same range of treatments. If one such hospital is excluded by all insurers, policymakers need not worry about anti-competitive effects.

A second point is that selective contracting in our framework is extreme in the sense that an insured patient who gets treatment at an excluded provider has to pay the full price of the treatment him/herself. Alternatively, with point of service options, an insured patient may face higher co-payments when visiting an excluded provider than a network provider. Although this reduces the size of the anti-competitive effects, it still implies that fewer consumers close to an excluded provider are willing to buy insurance (compared to the common outcome). The distribution of uninsured consumers will still be skewed, although less so. Hence the anti-competitive effects will not disappear. If in a certain case there are worries about the competitive effects of selective contracting, the regulator or competition authority may want to impose a maximal difference in co-payments between providers that are in and out of the insurer’s network. This will reduce the number of inframarginal uninsured customers close to the excluded provider.

We assumed in our model that consumers are differentiated along their risk aversion parameter σ . One may wonder whether we would find different results if instead differentiation comes from F , the probability of a health shock. It is not difficult to show that the basic mechanism – selective contracting leads to skewed demand and less aggressive competition in the market for uninsured – continues to hold in this case.¹⁷

Finally, we have assumed that insurers are homogeneous for consumers if they contract the same providers. However, insurers can differ in other dimensions. They may for example offer

¹⁷ Note that differentiation with respect to F introduces adverse selection in the model. Although this issue is not directly related to selective contracting, our assumption that insurers only offer contracts with full reimbursement is less applicable in this context.

different co-payments or reimburse a different set of treatments. If consumers have preferences over both providers and insurers, it is no longer obvious that outcome E in figure 4.1 is desirable. In this outcome, a consumer with a preference for, say, provider P_1 is forced to get insurance from I_a . The fact that providers and insurers are bundled in this outcome may lead to undesirable effects as consumers can no longer mix and match. The trade off between (horizontal) double marginalization in the common outcome and possible anti-competitive effects due to bundling is left for future research.

6 Conclusions

The analysis in this paper is motivated by the diverging predictions concerning selective contracting in the health care and industrial economics literature. The health literature stresses that selective contracting increases insurers' bargaining power. This leads to lower prices for insured treatments and hence lower health care costs. As health care expenditures are on the rise in most –if not all– developed countries, such reductions in treatment prices are welcome.

The (post Chicago) industrial economics literature stresses the possibilities for anti-competitive effects of such exclusionary arrangements. Using the general framework introduced by Bernheim and Whinston (1998) we have two main implications. First, since it is optimal for providers and insurers to use two-part tariffs, selective contracting does not directly reduce the price per treatment. We show that the option of selective contracting indeed increases rents for insurers. However, this rent is transferred using the fixed part of the two-part tariff. Because the price per treatment is not directly affected selective contracting does not necessarily make insurance cheaper for consumers.

Second, we show that selective contracting can indeed have anti-competitive effects. If exclusive contracts are concentrated among providers, uninsured prices tend to go up. With competing insurers, banning selective contracting tends to lead to higher prices than an outcome with exclusive contracts where each provider has at least one contract.

The policy implication is that selective contracting is fine as long as there are no excluded providers with (market) power to raise their prices on the uninsured market. If such providers do exist, the trade off between anti-competitive effects and possible efficiency gains needs to be resolved.

Clearly our analysis is not restricted to health insurance. Indeed selective contracting is also an issue in car insurance, where insurers may want to steer consumers to a restricted set of repair shops. The desirability of such behavior is hotly debated in for instance the US, Australia and the Netherlands. According to Sydney Morning Herald (2006) and Winter (2008) in the US slightly over half of all states have adopted anti-steering laws banning such behavior. According to the analysis above this is not the optimal policy response. It is better to allow steering as long as repair shops without a contract with an insurer do not have market power.

References

- Aghion, P. and P. Bolton, 1987, Contracts as a barrier to entry, *American Economic Review*, vol. 77, pp. 388–401.
- Bernheim, B.D. and M. Whinston, 1998, Exclusive dealing, *Journal of Political Economy*, vol. 106, no. 1, pp. 64–103.
- Capps, C., D. Dranove and M. Satterthwaite, 2003, Competition and market power in option demand markets, *RAND Journal of Economics*, vol. 4, no. 4, pp. 737–763.
- Dranove, D., 2000, *The economic evolution of American health care: from Marcus Welby to managed care*, Princeton University Press.
- Dranove, D. and W. White, 1999, *How Hospitals Survived*, American Enterprise Institute.
- Fombaron, N. and C. Milcent, 2007, The distortionary effect of health insurance on healthcare demand, PSE Working paper 2007-40.
- Gal-Or, E., 1997, Exclusionary equilibria in health-care markets, *Journal of Economics and Management Strategy*, vol. 6, pp. 5–43.
- Gaynor, M. and C. Ma, 1996, Insurance, vertical restraints and competition, unpublished, Carnegie Mellon University.
- Glied, S., 2000, Managed care, in A. Culyer and J. Newhouse, eds., *Handbook of health economics*, vol. 1, Elsevier.
- Gruber, J., 2008, Covering the uninsured in the united states, *Journal of Economic Literature*.
- Haas-Wilson, D., 2003, *Managed Care and Monopoly Power: The antitrust challenge*, Harvard University Press.
- Hadley, J. and J. Holahan, 2003, How much medical care do the uninsured use, and who pays for it?, *Health Affairs-Web Exclusive*.
- IOM, 2009, *America's uninsured crisis: Consequences for health and health care*, Institute of Medicine, National Academies Press.

- Ma, C.A., 1997, Option contracts and vertical foreclosure, *Journal of Economics & Management Strategy*.
- Rasmusen, E., M. Ramseyer and J. Wiley, 1991, Naked exclusion, *American Economic Review*, vol. 81, no. 5, pp. 1137–1145.
- Scott, A., 2000, Economics of general practice, in A. Culyer and J. Newhouse, eds., *Handbook of health economics*, vol. 1, Elsevier.
- Segal, I. and M. Whinston, 2000, Naked exclusion: comment, *American Economic Review*, vol. 90, pp. 296–309.
- Sloan, F., J. Rattliff and M. Hall, 2005, Impacts of managed care patient protection laws on health services utilization and patient satisfaction with care, *Health Services Research*, vol. 40(3), pp. 647–668.
- Spector, D., 2007, Exclusive contracts and demand foreclosure, PSE Working paper 2007-07.
- Sydney Morning Herald, 2006, NRMA may have to scrap repair system, (article by J. Pearlman).
- Town, R. and G. Vistnes, 2001, Hospital competition in HMO networks, *Journal of Health Economics*, vol. 20(5), pp. 733–753.
- Vita, M.G., 2001, Regulatory restrictions on selective contracting: an empirical analysis of any-willing-provider regulations, *Journal of Health Economics*, vol. 20, pp. 955–966.
- Winter, J., 2008, Schade sturing en marktfalen (steering and market failure), essay available through newspaper *Het Financieele Dagblad*
<http://www.fd.nl/artikel/10150044/nma-screent-autoverzekering>.
- Wright, J., 2008, Naked exclusion and the anticompetitive accommodation of entry, *Economics Letters*, vol. 98, pp. 107–112.

Appendix

Proof of lemma 1

First consider exclusive equilibria. Both providers make an offer for an exclusive contract. We study a (hypothetical) equilibrium where the contract is with provider P_1 . Both I and P_1 agree on their bilaterally optimal transfer price, and use a lump sum transfer t_1 from P_1 to I to take care of any redistribution of profits among them. This redistribution is, of course, constrained by the (non-accepted) offer made by P_2 , involving transfer t_2 . The payoffs of both offers to the three parties are then

	offer from 1	offer from 2
I :	$\pi_I^{(1)} + t_1$	$\pi_I^{(2)} + t_2$
P_1 :	$\pi_1^{(1)} - t_1$	$\pi_1^{(2)}$
P_2 :	$\pi_2^{(1)}$	$\pi_2^{(2)} - t_2$

Following Bernheim and Whinston (1998), an equilibrium in which 1's offer is accepted should satisfy

$$\pi_I^{(1)} + t_1 = \pi_I^{(2)} + t_2$$

The left hand side cannot be smaller or P_1 's contract would not be accepted, and it cannot be larger or P_1 would profitably lower t_1 and still be accepted. Secondly, we need that

$$\pi_2^{(1)} \geq \pi_2^{(2)} - t_2$$

or P_2 would profitably increase t_2 slightly and get accepted (as a result of the previous condition). Following Bernheim and Whinston (1998), we focus on the equilibrium where the latter condition is satisfied with equality. In other words, we consider the smallest possible t_1 and t_2 , since that is the equilibrium that maximizes both providers' payoffs (and providers make the offers). We can now solve

$$t_2 = \pi_2^{(2)} - \pi_2^{(1)}$$
$$t_1 = \pi_2^{(2)} - \pi_2^{(1)} + \pi_I^{(2)} - \pi_I^{(1)}$$

Thirdly, the equilibrium should satisfy

$$\pi_1^{(1)} - t_1 \geq \pi_1^{(2)}$$

or P_1 would prefer his offer being rejected. Inserting the expression for t_1 we get

$$\Pi_{total}^{(1)} \geq \Pi_{total}^{(2)}$$

or in other words, the exclusive contract is with the provider for which total sector profits are maximized. In a symmetric case we, of course, have equality, and hence two (mirror image) exclusive equilibria exist. This concludes the proof of the first part of the lemma.

Next consider an equilibrium where the insurer contracts with both providers. In this situation we have payoffs

$$I : \pi_I^c + t_1^c + t_2^c$$

$$P_1 : \pi_1^c - t_1^c$$

$$P_2 : \pi_2^c - t_2^c$$

and we again need to determine the equilibrium transfers. These transfers (and hence the insurer's share) are bounded from below by the requirement that no provider wants to deviate and offer an exclusive contract which gives both it and the insurer higher profits (at the expense of the rival provider). A profitable exclusive deviation t_1^e by provider P_1 , would satisfy

$$\pi_I^{(1)} + t_1^e > \pi_I^c + t_1^c + t_2^c$$

$$\text{and } \pi_1^{(1)} - t_1^e > \pi_1^c - t_1^c$$

simultaneously. Adding these two constraints we find that

$$t_2^c < \pi_I^{(1)} + \pi_1^{(1)} - \pi_I^c - \pi_1^c$$

for a profitable deviation to exist. A similar argument holds for t_1^c , and therefore in any common equilibrium transfers should at least be equal to these lower bounds:

$$t_i^c \geq \pi_I^{(j)} + \pi_j^{(j)} - \pi_I^c - \pi_j^c$$

Furthermore, since any provider can always choose not to supply (and leave the insurer to an exclusive contract with its rival), we have

$$\pi_i^c - t_i^c \geq \pi_i^{(j)}$$

$$\text{or } \Pi_{total}^c \geq \Pi_{total}^{(j)}$$

for a common equilibrium to exist. Suppose then that this holds. Again, the best equilibrium from the point of view of both providers has the bounds on t_i^c satisfied with equality,

$$t_i^c = \pi_I^{(j)} + \pi_j^{(j)} - \pi_I^c - \pi_j^c$$

while the deviating, non-accepted, exclusive offers satisfy

$$\pi_I^{(i)} + t_i^e = \pi_I^c + t_1^c + t_2^c$$

Solving for the transfers and inserting in the aggregate pay-offs completes the proof. *Q.E.D.*

Proof of lemma 2

From lemma 1 the insurer's profits under exclusion exceed profits under common contracts if

$$\Pi_{bilateral}^{(2)} - \pi_2^{(1)} > \Pi_{bilateral}^{(1)} + \Pi_{bilateral}^{(2)} - \Pi_{total}^c$$

or equivalently

$$\Pi_{total}^c > \Pi_{total}^{(1)}$$

which is true by assumption. *Q.E.D.*

Proof of proposition 1

We will demonstrate that for any fixed $\phi > (1-F)c$ it is the case that, first, $\frac{\phi}{1-F} = \tilde{\phi} > p_1^e(\phi)$ and second $p_2^e(\phi) > p_1^e(\phi) > p^c(\phi)$, assuming that $p^c(\phi)$ is unique. For convenience we restate the system of first order conditions combined with rational expectations that determines these prices. We have the common price $p^c(\phi)$ defined by the solution to the following equation

$$F^c(p) \equiv -\frac{1}{2t}(p-c)G(\sigma^c(\frac{1}{2}, \phi)) + \int_0^{\frac{1}{2}} G(\sigma^c(x, \phi)) dx = 0 \quad (6.1)$$

with

$$\sigma^c(x) = \frac{\tilde{\phi} - p}{F(p^2 + 2ptx)}$$

Exclusive prices $p_1^e(\phi), p_2^e(\phi)$ are the solution to the following system

$$F^1(p_1, p_2) \equiv -\frac{1}{2t}(p_1 - c)G(\sigma(\bar{x})) + \int_0^{\bar{x}} G(\sigma^1(x)) dx = 0 \quad (6.2)$$

$$F^2(p_1, p_2) \equiv -\frac{1}{2t}(p_2 - c)G(\sigma(\bar{x})) + \int_{\bar{x}}^1 G(\sigma^2(x)) dx = 0 \quad (6.3)$$

with

$$\begin{aligned} \sigma^1(x) &= \frac{\tilde{\phi} - p_1}{F(p_1^2 + 2p_1tx)}, \\ \sigma(\bar{x}) &= \frac{\tilde{\phi} - p_1}{F p_1 (p_2 + t)}, \\ \bar{x} &= \frac{1}{2} + \frac{p_2 - p_1}{2t}, \\ \sigma^2(x) &= \frac{\tilde{\phi} - (p_2 + t - 2tx)}{F(p_2 + t)(p_2 + t - 2tx)}. \end{aligned}$$

For proving the first inequality, $\tilde{\phi} > p_1^e(\phi)$, suppose by contradiction that $\tilde{\phi} \leq p_1^e(\phi)$. Then for each $x < \bar{x}$, everyone will choose insurance, or $\sigma^1(x) = 0$. For equation (6.2) to hold (where the integral equals zero), it must be the case that $p_1^e(\phi) = c$. But then $\tilde{\phi} \leq p_1^e(\phi) = c$ violates the condition on $\phi > (1-F)c$. Hence we find $\tilde{\phi} > p_1^e(\phi)$.

Next, we prove the second set of inequalities. From the first order conditions we first show that $p_2^e(\phi) > p_1^e(\phi)$. We then demonstrate that this implies $p_1^e(\phi) > p^c(\phi)$.

Step 1: $p_2^e(\phi) > p_1^e(\phi)$

From $F^2 - F^1$ we find after a change of variables (where we write p_1, p_2 instead of $p_1^e(\phi), p_2^e(\phi)$ to ease notation)

$$(p_2 - p_1) \frac{G(\sigma(\bar{x}))}{2t} = \int_0^{1-\bar{x}} G\left(\frac{\tilde{\phi} - (p_2 - t + 2tx)}{F(p_2 + t)(p_2 - t + 2tx)}\right) dx - \int_0^{\bar{x}} G\left(\frac{\tilde{\phi} - p_1}{F p_1(p_1 + 2tx)}\right) dx \quad (6.4)$$

We note that for $x < \frac{1}{2}$:

$$\frac{\tilde{\phi} - (p_2 - t + 2tx)}{F(p_2 + t)(p_2 - t + 2tx)} > \frac{\tilde{\phi} - p_1}{F p_1(p_1 + 2tx)} \quad (6.5)$$

so that $p_2 = p_1$ (and $\bar{x} = \frac{1}{2}$) cannot be a solution. Observe next that $p_2 < p_1$ cannot hold either: it only strengthens inequality (6.5), and since it causes $\bar{x} < \frac{1}{2}$, we have

$$\int_0^{1-\bar{x}} dx G(\sigma_2(p_2, 1-x)) > \int_0^{\bar{x}} dx G(\sigma_2(p_2, 1-x)) > \int_0^{\bar{x}} dx G(\sigma_1(p_1, x))$$

so that the right hand side of equation (6.4) above is positive, while the left hand side is negative. We conclude that $p_2^e(\phi) > p_1^e(\phi)$.

Step 2: $p_1^e(\phi) > p^c(\phi)$

Again simplifying notation by writing p_1, p_2, p^c , we observe that $F^1(p_1, p_2) = 0$ implicitly defines a continuous function $p_1(p_2)$. We are going to demonstrate that this function is such that $p_2 > p_1 \Rightarrow p_1 > p^c$.

First, since F^1 reduces to F^c when both arguments are equal, we have

$$p_1 = p_2 \Rightarrow p_1 = p^c$$

because of the assumption of a unique solution p^c to $F^c = 0$.

Next, we observe that

$$\frac{\partial F^1}{\partial p_2} = \frac{1}{2t} \frac{(p_1 - c)}{p_2 + t} \sigma(\bar{x}) g(\sigma(\bar{x})) + \frac{1}{2t} G(\sigma(\bar{x})) > 0$$

as long as $p_1 \geq c$, so F^1 is strictly increasing in p_2 for given p_1 . Since $F^1(p^c, p^c) = 0$, this implies that

$$F^1(p^c, p_2) = 0 \Rightarrow p_2 = p^c$$

From these two observations we have that the function $p_1(p_2)$ crosses the lines $p_1 = p_2$ and $p_1 = p^c$ only once, in their mutual crossing point $p_1 = p_2 = p^c$.

We now conclude this part of the proof by showing that for any $p_1 < p^c$ we also have $p_2 < p_1$ (which leads to a contradiction as step 1 proved that $p_2 > p_1$). We note that at

$p_1 = c < p^c$, $p_2 = p_1 - t$ (we need that $\bar{x} = 0$ otherwise $F^1(c, p_2) = 0$ is not satisfied). Based on the single crossing point just demonstrated, we have that $p^c > p_1 > p_2$ for all $p_2 < p^c$.

As a result, from step 1 we have that $p_2^e(\phi) > p_1^e(\phi)$, and from step 2 we learn that this can only solve the system if also $p_1^e(\phi) > p^c(\phi)$. *Q.E.D.*

Proof of theorem 1

In order to prove this result, we first introduce and prove four lemmas.

Lemma 5. *In the common equilibrium, ϕ will be chosen to optimize total sector profits.*

Proof of lemma 5 First, note that p_c only depends on transfer prices \tilde{p}_1, \tilde{p}_2 through ϕ . The insurance premium ϕ itself is a function of \tilde{p}_1, \tilde{p}_2 . Write common (reduced form) profits for each firm as $\pi_I(\phi(\tilde{p}_1, \tilde{p}_2), \tilde{p}_1, \tilde{p}_2)$, $\pi_i(\phi(\tilde{p}_1, \tilde{p}_2), \tilde{p}_i)$ (for $i = 1, 2$). Optimizing bilateral profits then amounts to setting the total derivative of the sum $\pi_I + \pi_i$ w.r.t. \tilde{p}_i to zero:

$$\frac{\partial \pi_I}{\partial \phi} \frac{\partial \phi}{\partial \tilde{p}_i} + \frac{\partial \pi_i}{\partial \phi} \frac{\partial \phi}{\partial \tilde{p}_i} + \frac{\partial \pi_I}{\partial \tilde{p}_i} + \frac{\partial \pi_i}{\partial \tilde{p}_i} = 0$$

We now observe that $\frac{\partial \pi_I}{\partial \phi} = 0$ (as the insurer chooses ϕ to maximize its profits). The sum of the last two terms is zero as well since both profits only depend explicitly on \tilde{p}_1 through the transfer between them; in the sum $\pi_I + \pi_i$ this cancels. We are therefore left with $\frac{\partial \pi_i}{\partial \phi} = 0$. Since this holds for both $i = 1, 2$, we find in the optimum that ϕ maximizes total (common) profits, i.e., the sum $\pi_I + \pi_1 + \pi_2$. *Q.E.D.*

Lemma 6. *For each $p_r \geq 0$ we have that*

$$\max_{\phi} \Pi_{total}^{(1)}(\phi, \max\{p_r, p_1^e(\phi)\}, p_2^e(\phi)) \geq \max_{\phi} \Pi_{total}^{(1)}(\phi, p_1^e(\phi), p_2^e(\phi)) \quad (6.6)$$

Proof of lemma 6 If $p_1^e(\phi) \geq p_r$ the result obviously holds (with equality). Assume $p_1^e(\phi) < p_r$. Then we know from proposition 1 that $\tilde{\phi} > p_1^e(\phi)$ and $p_2^e(\phi) > p_1^e(\phi)$. Starting from $p_1^e(\phi) < p_r$, increasing p_1 to p_r has three effects:

- Profits from uninsured customers that continue to go to P_1 increase,
- Some uninsured customers switch from P_1 to provider P_2 with the higher margin (as $p_2^e(\phi) > p_1^e(\phi)$ by proposition 1) and
- Some uninsured customers that used to go to P_1 decide to take insurance which has a higher margin as $\tilde{\phi} > p_1^e(\phi)$.

All three effects raise sector profits and hence the left hand side of equation (6.6) indeed exceeds the right hand side. *Q.E.D.*

Lemma 7. *In a subgame perfect common equilibrium where $p_2 \leq p_r$ is binding (i.e. $p_2 = p_r$), we have*

$$\tilde{\phi} > p_r \quad (6.7)$$

$$p_1 \geq p_r \quad (6.8)$$

with $p_1 = p_r$ if we assume that the upperbound p_r holds for p_1 as well.

Proof of lemma 7

First we prove inequality (6.7) by contradiction. Suppose that the inequality does not hold, i.e. assume that $\tilde{\phi} \leq p_r$. We consider two cases:

- $p_1 < \tilde{\phi} (\leq p_r = p_2)$
- $p_1 \geq \tilde{\phi} (\leq p_r = p_2)$

In the first case all customers close to P_2 take out insurance (as it is cheaper in expected terms than getting uninsured treatment). Let \tilde{x} denote the customer (with $\sigma = 0$) furthest away from P_1 without insurance. It easily seen that $\tilde{x} > \frac{1}{2}$. We find $\tilde{x} = \frac{1}{2} + \frac{\tilde{\phi} - p_1}{2t} \leq \frac{1}{2} + \frac{p_2 - p_1}{2t} = \bar{x}$ where \bar{x} denotes the uninsured customer indifferent between going to P_1 and P_2 . However, this implies that in the final stage of the game p_1 does not maximize P_1 's profits. If p_1 is raised, P_1 gains over all its inframarginal uninsured customers and it loses at the margin $(p_1 - c)G(\sigma(\tilde{x})) = 0$ by the definition of \tilde{x} . Consider the second case with $p_1 \geq \tilde{\phi}$. Then everyone takes out insurance and $p_1, p_2 \geq \tilde{\phi}$ is indeed a Nash equilibrium. However, it is not subgame perfect. To see this, consider a consumer at $x = \frac{1}{2}$ with $\sigma = 0$ who deviates and does not buy insurance. At the final stage, P_1 and P_2 compete (without inframarginal uninsured consumers) at price $p_1 = p_2 = c$. Since consumers have rational expectations, they foresee that P_1 and P_2 will lower their price in the final stage. Hence $p_1, p_2 \geq \tilde{\phi}$ is not a subgame perfect equilibrium.

Therefore we find $\tilde{\phi} > p_r$.

Next we prove inequality (6.8) by contradiction. Hence assume that $p_1 < p_r$ while $p_2 \leq p_r$ is binding. Then the first order conditions for p_1, p_2 in a common outcome can be written as

$$H^1(p_1, p_r) \equiv -\frac{1}{2t}(p_1 - c)G(\sigma(\bar{x})) + \int_0^{\bar{x}} G(\sigma^1(x)) dx = 0$$

$$H^2(p_1, p_r) \equiv -\frac{1}{2t}(p_r - c)G(\sigma(\bar{x})) + \int_{\bar{x}}^1 G(\sigma^2(x)) dx \geq 0$$

with

$$\sigma^1(x) = \frac{\tilde{\phi} - p_1}{F(p_1^2 + 2p_1tx)},$$

$$\sigma(\bar{x}) = \frac{\tilde{\phi} - p_1}{Fp_1(p_r + t)},$$

$$\bar{x} = \frac{1}{2} + \frac{p_r - p_1}{2t},$$

$$\sigma^2(x) = \frac{\tilde{\phi} - p_r}{F p_r (p_r + 2t(1-x))}.$$

From $H^2 - H^1$ we find after a change of variables

$$-(p_r - p_1) \frac{G(\sigma(\bar{x}))}{2t} + \int_0^{1-\bar{x}} G\left(\frac{\tilde{\phi} - p_r}{F(p_r^2 + 2p_r t x)}\right) dx - \int_0^{\bar{x}} G\left(\frac{\tilde{\phi} - p_1}{F(p_1^2 + 2p_1 t x)}\right) dx \geq 0 \quad (6.9)$$

We note that for $p_1 < p_r$:

$$\frac{1 - \bar{x} < \bar{x}}{\frac{\tilde{\phi} - p_r}{F(p_r^2 + 2p_r t x)}} < \frac{\tilde{\phi} - p_1}{F(p_1^2 + 2p_1 t x)}$$

which implies that equation (6.9) cannot hold. This contradiction implies $p_1 \geq p_r$. *Q.E.D.*

Lemma 8. *If $p_2 \leq p_r$ is binding, then $p_1^e(\phi) = p^c(\phi)$. That is, the functions linking P_1 's uninsured price to the insurance premium ϕ are the same under common and exclusive contracts.*

Proof of lemma 8 First, note that the uninsured consumer indifferent between providers P_1 and P_2 is given by

$$\bar{x}(p_1) = \frac{1}{2} + \frac{p_r - p_1}{2t} \quad (6.10)$$

Second, the first order condition for p_1 can be written as $H^1(p_1, p_r) = 0$ where H^1 and σ^1 are defined in the proof of lemma 7 above. Since $\bar{x}(p_1)$, H^1 and σ^1 hold for both the common and exclusive outcomes, we find that the function $p_1(\phi)$ is the same for common and exclusive if $p_2 \leq p_r$ is binding. *Q.E.D.*

Having proved these lemmas, we can now proceed to proving the theorem. By Lemma 1, to prove the theorem we need to show that under the cap on P_2 's uninsured price, $p_2 \leq p_r$, total profits under common representation are always larger than total profits under exclusivity. In the equations below $p_2^e(\phi)$ denotes P_2 's best response under the restriction that this price cannot exceed p_r . That is, it denotes the minimum of p_r and the solution to equation (6.3).¹⁸

The result follows from

$$\Pi_{total}^c = \max_{\phi} \{ \pi_1^c(\phi, p^c(\phi), p_r) + \pi_1^c(\phi, p^c(\phi), p_r) + \pi_2^c(\phi, p^c(\phi), p_r) \} \quad (6.11)$$

$$= \max_{\phi} \{ \pi_{total}^c(\phi, \max\{p^c(\phi), p_r\}, p_r) \} \quad (6.12)$$

$$> \max_{\phi} \{ \pi_{total}^{(1)}(\phi, \max\{p_1^e(\phi), p_r\}, p_r) \} \quad (6.13)$$

$$= \max_{\phi, p_2 \leq p_r} \{ \pi_{total}^{(1)}(\phi, \max\{p_1^e(\phi), p_r\}, p_2) \} \quad (6.14)$$

$$\geq \max_{\phi} \{ \pi_{total}^{(1)}(\phi, \max\{p_1^e(\phi), p_r\}, p_2^e(\phi)) \} \quad (6.15)$$

¹⁸ Note that the proof also applies if p_r is the upperbound on p_1 . In that case, one should read the proof with $p_1(\phi) \leq p_r$ in mind.

$$\geq \max_{\phi} \left\{ \pi_{total}^{(1)}(\phi, p_1^e(\phi), p_2^e(\phi)) \right\} \quad (6.16)$$

$$\geq \max_{\phi} \left\{ \pi_I^{(1)}(\phi, p_1^e(\phi), p_2^e(\phi)) + \pi_1^{(1)}(\phi, p_1^e(\phi), p_2^e(\phi)) \right\} + \pi_2^{(1)}(\phi^*, p_1^e(\phi^*), p_2^e(\phi^*)) \quad (6.17)$$

$$= \Pi_{total}^{(1)} \quad (6.18)$$

Line (6.11) follows from the assumption that the cap binds for p_2 in the common equilibrium, and the fact that in common equilibrium ϕ maximizes total profits (lemma 5 above). Equation (6.12) follows from lemma 7. Line (6.13) looks at the exclusive situation where the insured can only visit provider 1, where we use that the function $p_1(\phi)$ is the same under common and exclusive contracts (keeping p_2 fixed). If P_2 's uninsured price is still fixed at the cap, total sector profits can only go down, since consumers on the righthand side of the beach (x close to 1) are less likely to choose the (higher margin: see (6.7)) insurance contract. Line (6.14) asserts that in the optimum, an industry profit maximizer would choose P_2 's uninsured price at the cap in the exclusive situation. Indeed, lowering p_2 has two effects:

- Fewer people take insurance which has a higher margin (again see (6.7)) and
- Some uninsured switch from P_1 to P_2 while $\max\{p_1^e(\phi), p_r\} \geq p_r \geq p_2$.

Both effects reduce sector profits and hence the equality in (6.14) holds. Line (6.15) restricts P_2 's uninsured price to its equilibrium best response (subject to the cap) and hence profits cannot exceed (6.14). In order to prove the inequality in equation (6.16) we consider two cases:

- In case $p_2^e(\phi) = p_r$, lemma 7 implies $p_1^e(\phi) \geq p_r$ and hence the equation holds with equality;
- In case $p_2^e(\phi) < p_r$ we know from lemma 6 that the inequality holds.

P_2 's profits in line (6.17) are evaluated at the value of ϕ (denoted by ϕ^*) that maximizes bilateral profits for I and P_1 . This inequality is evident. *Q.E.D.*

Proof of proposition 2

Consider the case where P_1 has exclusive contracts with I_a and I_b . In this case, I_a and I_b offer identical products and their profits are zero. Hence we find $\phi^{ee} = \tilde{p}_1^{ee}$ and P_1 chooses \tilde{p}_1^{ee} to maximize the sum of profits of P_1, I_a and I_b . This is exactly the same expression as equation (3.6) in the case with only one insurer. Hence, here we get the same ϕ and consequently the same uninsured prices p_1, p_2 as above with exclusion and one insurer (see lemma 4).

Let π_i^{ee} denote the profits of provider i when i has exclusive contracts with both I_a and I_b . In this case, the profits for $j \neq i$ are denoted π_j^{00} . As noted, in this case insurer profits equal zero. If each provider has one exclusive contract, profits of provider i are denoted by π_i^e . Profits of insurer k are then denoted by π_k^e . Note that these profits can be positive, as insurers offer differentiated products in this case.

The transfer t^{ee} offered by provider P_1 to both insurers has to satisfy the following inequalities

$$\pi_1^{ee} - 2t^{ee} \geq \pi_1^{00} \quad (6.19)$$

$$\pi_2^{00} + t^{ee} \geq \pi_2^e + \pi_a^e \quad (6.20)$$

$$\pi_2^{00} + 2t^{ee} \geq \pi_2^{ee} \quad (6.21)$$

$$\pi_1^{ee} - t^{ee} \geq \pi_1^e + \pi_a^e \quad (6.22)$$

The first inequality says that P_1 prefers to have both exclusive contracts rather than none. The second inequality states that the coalition of P_2 and I_a cannot gain by deviating to a bilateral exclusionary contract. The third inequality asserts that the coalition P_2, I_a and I_b cannot deviate to exclusive contracts (*i.e.* the mirrored EE outcome). Finally, P_1 and I_a should not prefer to switch from EE to E .

Using the symmetry of the outcomes (*e.g.* $\pi_1^{ee} = \pi_2^{ee}$), adding equation (6.19) to two times equation (6.20) gives:

$$\pi_1^{ee} + \pi_2^{00} \geq \pi_1^e + \pi_2^e + \pi_a^e + \pi_b^e \quad (6.23)$$

The same condition results from the sum of (6.20) and (6.22). In words, we see outcome EE if total industry profits in case one provider contracts exclusively with both insurers is higher than total industry profits in the outcome where each provider contracts exclusively with one insurer. This inequality is actually implied by the assumption we made that $\Pi_{total}^{(1)} > \Pi_{total}^c$ in lemma 1 holds. To see this, first note that because the outcomes are identical, also the profits are equal in EE and the exclusive equilibrium with a monopoly insurer. That is, $\Pi_{total}^{(1)} = \pi_1^{ee} + \pi_2^{00}$. Next, in the E outcome, two symmetrically placed provider-insurer combinations compete. In the symmetric equilibrium where both choose the same ϕ^e , we know that non-insured prices are given by equation (3.2), as in the common equilibrium with a monopolist insurer. Further, in the monopoly insurance common outcome, ϕ is chosen to maximize industry profits (lemma 5). Hence we find

$$\Pi_{total}^c \geq \pi_1^e + \pi_2^e + \pi_a^e + \pi_b^e$$

Summarizing we have

$$\pi_1^{ee} + \pi_2^{00} = \Pi_{total}^{(1)} > \Pi_{total}^c \geq \pi_1^e + \pi_2^e + \pi_a^e + \pi_b^e$$

and inequality (6.23) is satisfied. We therefore prove that an exclusive equilibrium exists, and that it takes the form of the EE situation.

Next we may check that equilibria involving non-exclusive contracts do not exist under the assumptions. We may distinguish two types of common equilibria: one where both insurers contract with both providers, the CC -equilibrium, and one where one insurer contracts with both providers and the other has an exclusive contract with provider P_1 only, the CE -equilibrium. A

similar reasoning as above shows that neither common equilibrium can exist in this case.

Consider first *CC*. The following two inequalities are necessary conditions for a *CC* equilibrium to exist in the case with two insurers:

$$\pi_1^{cc} + \pi_a^{cc} + \pi_b^{cc} + t_{2a}^{cc} + t_{2b}^{cc} \geq \pi_1^{ee} \quad (6.24)$$

$$\pi_2^{cc} - t_{2a}^{cc} - t_{2b}^{cc} \geq \pi_2^{00} \quad (6.25)$$

The first inequality implies that P_1, I_a and I_b have no incentive to deviate from the common outcome to the *EE* outcome. The second inequality implies that P_2 has no incentive to withdraw its contracts. Adding these two inequalities yields

$$\pi_1^{cc} + \pi_2^{cc} + \pi_a^{cc} + \pi_b^{cc} \geq \pi_1^{ee} + \pi_2^{00}$$

Again note that the industry profits in the common outcome in case of two insurers cannot exceed industry profits with one insurer as industry profits are maximized with one insurer (lemma 5). Given our assumption $\Pi_{total}^{(1)} > \Pi_{total}^c$ the inequality above has to be violated.

Similarly, for the *CE* case, stability requires that

$$\pi_1^{ce} + \pi_a^{ce} + \pi_b^{ce} + t_{2b}^{ce} \geq \pi_1^{ee} \quad (6.26)$$

$$\pi_2^{ce} - t_{2b}^{ce} \geq \pi_2^{00} \quad (6.27)$$

and addition of these conditions yields the familiar total profit condition. Both insurers necessarily charge the same insurance premium, because they compete in homogeneous products for consumers that want to go to provider 1. By the same considerations as before, *CE* profits are necessarily lower than the monopolist insurer common profits, and we find that *CE* cannot be an equilibrium. *Q.E.D.*

Proof of proposition 3

We demonstrate that at the monopoly optimum value ϕ^* , either provider will have an incentive to drive up the premium.

Under insurer competition we have $\tilde{\phi} = \frac{1}{2}(\tilde{p}_1 + \tilde{p}_2)$. Either insurer will price at its marginal costs and make zero profits. Provider P_1 will take \tilde{p}_2 as given and choose \tilde{p}_1 to optimize his profits (which now equal his joint profits with the insurer, the latter's profits being zero). Writing $\tilde{p}_1 = 2\tilde{\phi} - \tilde{p}_2$ we have

$$\tilde{\pi}_1 = \int_0^{\frac{1}{2}} (1-G)dx(2\tilde{\phi} - \tilde{p}_2 - c) + \int_0^{\frac{1}{2}} Gdx(p_c(\tilde{\phi}) - c) \quad (6.28)$$

Recall from lemma 5 that ϕ^* maximizes aggregate profits,

$$\tilde{\pi}_{total} = 2 \int_0^{\frac{1}{2}} (1-G)dx(\tilde{\phi} - c) + 2 \int_0^{\frac{1}{2}} Gdx(p_c(\tilde{\phi}) - c)$$

Using the first order condition of this optimum, at ϕ^* the derivative of (6.28) with respect to $\tilde{\phi}$ equals

$$\frac{\partial}{\partial \tilde{\phi}} \tilde{\pi}_1 = \frac{\partial}{\partial \tilde{\phi}} \int_0^{\frac{1}{2}} (1-G) dx (\tilde{\phi} - \tilde{p}_2)$$

Since at the hypothetical equilibrium, $\tilde{p}_2 = \tilde{\phi}^*$, we find that at this value

$$\frac{\partial}{\partial \tilde{\phi}} \tilde{\pi}_1 = \int_0^{\frac{1}{2}} (1-G) dx > 0$$

so P_1 has an incentive to drive up $\tilde{\phi}$.

Q.E.D.

Proof of proposition 4

For the E-equilibrium we define total profits for either vertical chain (indexed by $1a$ and $2b$) in terms of reduced form profit functions, depending only on the two insurers' premiums, ϕ_a, ϕ_b (since uninsured prices depend on these two insurance premiums).

$$\Pi_{1a} = \tilde{\pi}_a(\phi_a, \phi_b) + \tilde{\pi}_1(\phi_a, \phi_b)$$

$$\Pi_{2b} = \tilde{\pi}_b(\phi_a, \phi_b) + \tilde{\pi}_2(\phi_a, \phi_b)$$

This is a simple two-player game in which either chain selects its Nash-optimal ϕ_α given its opponent's choice ϕ_β ($\beta \neq \alpha$). The equilibrium is characterized by the system of two first-order conditions. We assume there is a unique symmetric equilibrium $\phi_a = \phi_b = \phi^E$.

The common monopoly insurer game is rather similar: here we saw the equilibrium consists of the single ϕ that optimizes total sector profits. Profits in this case are equal to

$$\Pi^c(\phi) = \Pi_{1a}(\phi, \phi) + \Pi_{2b}(\phi, \phi)$$

i.e. they are related to the single chain E-profits subject to the condition that $\phi_1 = \phi_2$.

The first order conditions for Π^c under this constraint reduce to (on eliminating the Lagrange multiplier)

$$\frac{\partial \Pi_{1a}}{\partial \phi_a} + \frac{\partial \Pi_{1a}}{\partial \phi_b} + \frac{\partial \Pi_{2b}}{\partial \phi_a} + \frac{\partial \Pi_{2b}}{\partial \phi_b} = 0$$

This differs from the sum of the E-equilibrium FOCs by the cross derivatives, $\frac{\partial \Pi_\alpha}{\partial \phi_\beta}$ ($\beta \neq \alpha$).

Assuming a unique solution for the common $\phi = \phi^c$ we find that $\phi^c \geq \phi^E$ as long as

$$\frac{\partial \Pi_{1a}}{\partial \phi_b}, \frac{\partial \Pi_{2b}}{\partial \phi_a} \geq 0 \text{ at } \phi^E.$$

The remainder of this proof shows that indeed $\frac{\partial \Pi_{1a}}{\partial \phi_b}, \frac{\partial \Pi_{2b}}{\partial \phi_a} \geq 0$ at ϕ^E .

To check this (note that by symmetry we only need to check one), let us analyze the E-equilibrium first order conditions in more detail. Although we consider the symmetric

equilibrium, we need to worry about first-order deviations from symmetry as say ϕ_b increases a bit beyond ϕ^E .

First, if someone chooses an insurer, which insurer is preferred to him? The consumer at x indifferent between either insurer has risk aversion parameter $s(x)$ defined by:

$$s(x, \phi_a, \phi_b) = \frac{\phi_a - \phi_b}{Ft^2(1-2x)} - \frac{1}{Ft}$$

and for $\phi_b > \phi_a$, only consumers on the righthand side of the market with $\sigma > s(x)$ will consider the righthand side insurer.

Second, each consumer will trade off connecting with his preferred insurer and not insuring at all. This gives rise to the function $\sigma(x)$.

Suppose again that $\phi_b > \phi_a$. We define the point \bar{x} as before, the location where uninsured are indifferent between either hospital. We define the point $\tilde{x} > \frac{1}{2}$ where

$\sigma(\tilde{x}, \phi_a, \phi_b) = s(\tilde{x}, \phi_a, \phi_b)$.¹⁹ Marginally insured consumers between 0 and \bar{x} choose between I_a and P_1 , those between \bar{x} and \tilde{x} choose between I_a and P_2 and those with $x > \tilde{x}$ choose between I_b and P_2 . So we define $\sigma(x, \phi_a, \phi_b)$ separately for the three regimes.

$$\sigma(x, \phi_a, \phi_b) = \begin{cases} \frac{\phi_a - p_1}{Fp_1(p_1 + 2tx)} & x < \bar{x} \\ \frac{\phi_a - (p_2 + t) + 2tx}{F(p_2 + t)(p_2 + t - 2tx)} & \bar{x} < x < \tilde{x} \\ \frac{\phi_b - p_2}{Fp_2(p_2 + 2t(1-x))} & \tilde{x} < x \end{cases}$$

Again, prices p_i are defined implicitly by

$$p_1 - c = 2t \frac{\int_0^{\bar{x}} G(\sigma(x, \phi_a, \phi_b))}{G(\sigma(\bar{x}, \phi_a, \phi_b))}$$

$$p_2 - c = 2t \frac{\int_{\bar{x}}^1 G(\sigma(x, \phi_a, \phi_b))}{G(\sigma(\bar{x}, \phi_a, \phi_b))}$$

For defining the profits, we also need the value x' , defined by $s(x'(x, \phi_a, \phi_b)) = \bar{\sigma}$, the supremum of g 's support. Then profits for the $1a$ -chain, when ϕ_b is slightly higher than ϕ_a , are

$$\begin{aligned} \Pi_{1a} &= \int_0^{\bar{x}} G(\sigma(x, \phi_a, \phi_b)) dx (p_1 - c) \\ &+ \int_0^{x'} (1 - G(\sigma(x, \phi_a, \phi_b))) dx (\phi_a - c) \\ &+ \int_{x'}^{\bar{x}} (G(s(x, \phi_a, \phi_b)) - G(\sigma(x, \phi_a, \phi_b))) dx (\phi_a - c) \end{aligned}$$

Now we are going to take ϕ_b -derivatives in the symmetric equilibrium, at $\phi_a = \phi_b = \phi^E$, where $p_{1,2} = p^E$. Note that in this equilibrium, we have $\bar{x} = x' = \tilde{x} = \frac{1}{2}$. This will cause several terms to vanish. We find

$$\begin{aligned} \frac{\partial \Pi_{1a}}{\partial \phi_b} &= \frac{\partial \bar{x}}{\partial \phi_b} G\left(\sigma\left(\frac{1}{2}, \phi^E, \phi^E\right)\right) (p^E - c) - \int_0^{\frac{1}{2}} \frac{\partial \sigma}{\partial p_1} \frac{\partial p_1}{\partial \phi_b} g(\sigma(x, \phi^E, \phi^E)) (\phi^E - p^E) dx \\ &+ \int_0^{\frac{1}{2}} G(\sigma(x, \phi^E, \phi^E)) dx \frac{\partial p_1}{\partial \phi_b} \end{aligned}$$

¹⁹ Because $\phi_b > \phi_a$ we have that $\lim_{x \rightarrow \frac{1}{2}} s(x, \phi_a, \phi_b) = +\infty$ and hence $\tilde{x} > \frac{1}{2}$.

Since $\frac{\partial \sigma}{\partial p_1} < 0$, all terms are nonnegative if

$$0 \leq \frac{\partial p_1}{\partial \phi_b} \leq \frac{\partial p_2}{\partial \phi_b}.$$

We use the following two steps to show that these two inequalities hold. It then follows from $\partial \Pi_{1a}/\partial \phi_b \geq 0$ (and by symmetry $\partial \Pi_{2b}/\partial \phi_a \geq 0$) that $\phi^c \geq \phi^E$.

Step 1: $\frac{\partial p_2}{\partial \phi_b} \geq \frac{\partial p_1}{\partial \phi_b}$

For $\phi_b > \phi_a$, we find by subtracting the two implicit equations for the prices (after a change of variables)

$$(p_2 - p_1) \frac{G(\sigma(\bar{x}, \phi_a, \phi_b))}{2t} = \int_0^{1-\bar{x}} dx G\left(\frac{\phi_b - p_2}{F p_2 (p_2 + 2tx)}\right) + \int_{1-\bar{x}}^1 dx G\left(\frac{\phi_a - (p_2 - t + 2tx)}{F(p_2 + t)(p_2 - t + 2tx)}\right) - \int_0^{\bar{x}} dx G\left(\frac{\phi_a - p_1}{F p_1 (p_1 + 2tx)}\right)$$

By similar logic as in the proof of proposition 1 (step 1), we conclude that $p_2 > p_1$. This in turn implies $\frac{\partial p_2}{\partial \phi_b} \geq \frac{\partial p_1}{\partial \phi_b}$ at $\phi_a = \phi_b$.

Step 2: $\partial p_1/\partial \phi_b \geq 0$

We now focus on the defining equation for p_1 . Note that this does not depend directly on ϕ_b , but only indirectly through \bar{x} . We know from the first step that $\frac{\partial \bar{x}}{\partial \phi_b} \geq 0$ because $\frac{\partial (p_2 - p_1)}{\partial \phi_b} \geq 0$.

We can now follow the exact same arguments as in step 2 of the proof of proposition 1 to demonstrate that the function $p_1(p_2)$ implied by the price condition only crosses $p_1 = p_2$ once, namely at the point $p_1 = p_2 = p_c$ (evaluated at $\phi_a = \phi^E$). Since for $\phi_b > \phi_a$ we know that $p_2 > p_1$, we again find that $\frac{\partial p_1}{\partial \phi_b} \geq 0$ at the ϕ^E equilibrium.

Combining these two steps with the previous result, we find that $\partial \Pi_{1a}/\partial \phi_b, \partial \Pi_{2b}/\partial \phi_a \geq 0$ and thus $\phi^E \leq \phi^c$. *Q.E.D.*